



A Method
for Analyzing
Mechanized and Robotized Production Processes
on the Building Site.

door
Frans van Gassel,
Technische Universiteit Eindhoven,
Faculteit Bouwkunde,
Vakgroep BPU, Sectie Uitvoeringstechniek.

Artikel en lezing
op het 12th
International Symposium
on Automation and Robotics in Construction
ISARC XII.

30 May - 1 June 1995

Warsaw, Poland



Organized by the
Building Mechanization and Mineral
Mining Research Institute, Warsaw, Poland

A method for analysing mechanized and robotized production processes on the building site

Ir F.J.M. van Gassel

Eindhoven University of Technology, Faculty of Building and Architecture,
Eindhoven, The Netherlands.

Abstract

This article describes a method for analysing mechanized and robotized production processes on the building site. The method is based on the theory of system analysis, which describes information, material and energy transformation processes. The basic diagram of the Worker Equipment System was developed for this purpose. Their the concepts of mechanization and robotization are explained, followed by the mechanization graph, possible mechanization phases, and the product and process development graph. Finally, future building site developments are indicated.

1. INTRODUCTION

Students who choose Construction Engineering as their main specialization at Eindhoven University of Technology, Faculty of Building and Architecture, are required to take the subject 'Mechanization on the building site'. For this subject, a method has been developed for analysing mechanized and robotized production processes on the building site.

Increasingly, production processes are being mechanized and robotized at building sites in order to reduce production times and costs, improve working conditions, and to allow work to be performed that people cannot do. Particularly in the latter instance, production processes are already considerably robotized.

2. WORKER EQUIPMENT SYSTEM

People and equipment, both performing specific tasks, are necessary in order to transform construction materials into a building. The transformation process is schematically depicted in a diagram: the basic diagram of the Worker Equipment System. See figure 1.

The diagram used here is based on system analysis. Information, materials and energy are transformed by the Worker Equipment System from an initial to a final situation [Maas]. The number of tasks the equipment and the worker have to perform are represented by the size of the surface in the diagram.

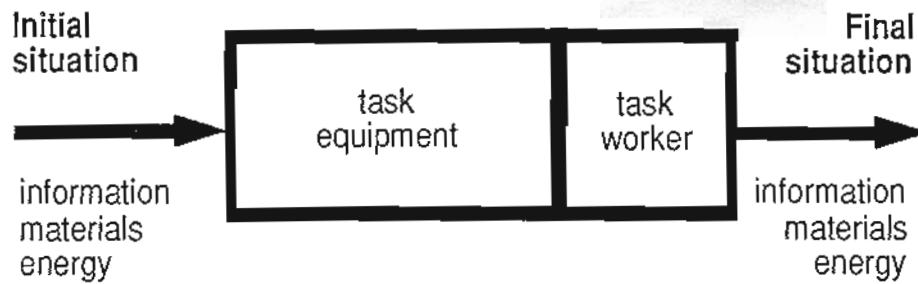

Figure 1. Basic diagram of the Worker Equipment System.

As an example, the basic diagram is applied to a production process in which large, heavy wall elements are taken from a lorry and assembled on a facade. This assembly can be divided into a number of constituent processes: attachment of the element to the hoisting hook, transportation to the location where it is to be assembled, and turning the element to the desired position. The tasks performed by equipment and those performed by people can be indicated for each constituent process. See figure 2.

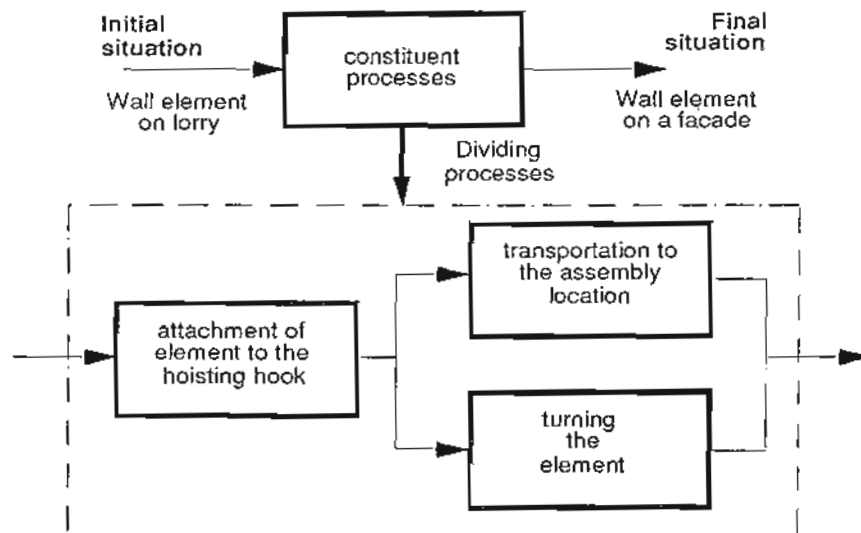

Figure 2. Transportation of wall elements.

3. MECHANIZATION AND ROBOTIZATION CONCEPTS

The mechanization concept is defined on the basis of the diagram in figure 1: "Mechanization is the shift of tasks from worker to equipment." This concept is schematically represented in figure 3.

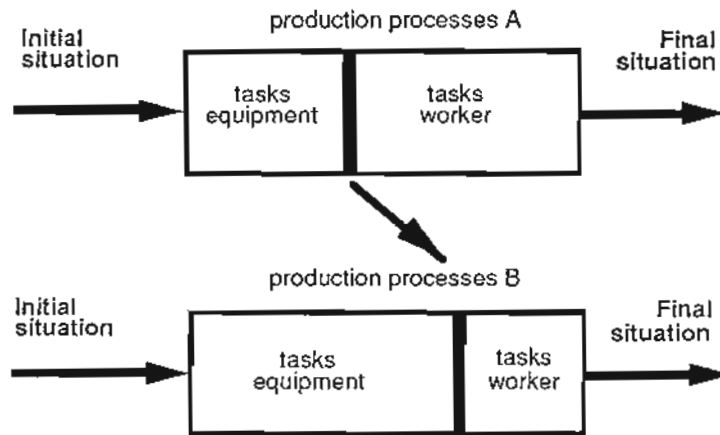

Figure 3. The mechanization concept.

Robotization is a special type of mechanization. Here, all tasks are shifted from the worker to the equipment. See figure 4. Control and support activities are not included in these tasks, because they are not directly related to the production process.

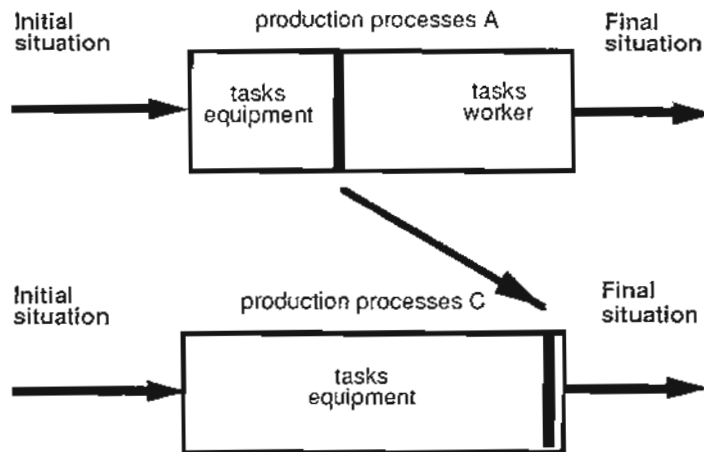

Figure 4. The robotization concept.

4. THE MECHANIZATION GRAPH

The tasks workers and equipment carry out can be divided into energy tasks and control tasks.

Three situations are considered for the performance of energy tasks:

- the equipment does not supply energy
- the equipment supplies a certain amount of driving energy
- the equipment supplies all the driving energy and the worker only has to operate the controls.

Driving energy means, for example, the revolving and linear motion of a drill and the supply of energy necessary to hold the equipment in a steady position. The latter can be achieved by placing the equipment on a stand.

Control task classification is based on Guo and Tucker's machine line arrangement [Guo]. This classification comprises the following levels: hand tools, manually controlled devices, telecontrolled devices, pre-programmed devices and cognitive robots. At the beginning of the line, all tasks are carried out by people and at the end by machines.

On a graph, energy tasks are placed on the vertical axis and control tasks on the horizontal axis, which gives us the mechanization graph. See figure 5.

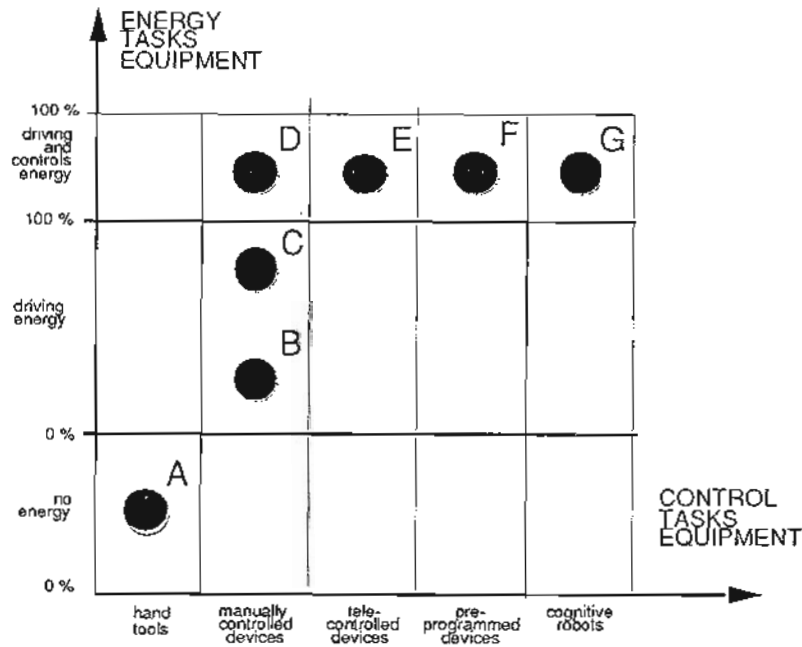

Figure 5. Mechanization graph.

An (element of a) worker-equipment system can be placed in the squares of the graph.

Examples:

- A: The laying of bricks with the aid of a mason's trowel.
- B: The drilling of a hole in a wall with an electric drill.
- C: The drilling of a hole in a wall with an electric drill that has been placed on a guide and the starting of which is also electrically driven.
- D: The riding of an operator on an excavator.
- E: The moving of loads with a crane that is remotely controlled.
- F: The laying of bricks by a robot that places bricks and mortar according to instructions.
- G: The digging of a trench in the ground by an intelligent excavator that can make decisions on the basis of observations.

5. MECHANIZATION PHASES

It is now possible to indicate the mechanization phases on the mechanization graph.

The following phases can be distinguished:

- optimization of tools
- use of drives
- use of guides
- use of control equipment
- use of remote control
- use of computers
- use of artificial intelligence.

The mechanization phases are represented in the mechanization graph in figure 6. The phases above are based on the mechanization of existing situations. Entirely new production processes, however, can be designed as well. Here, it is only possible to represent the end of the mechanization phase on the graph.

An increasing degree of technology is necessary in order to complete the mechanization phases. This requires knowledge of:

- materials and construction products
- what workers can do (ergonomics)
- drive technology, guides and manipulators
- machine controls, remote controls and programming technologies
- sensors and artificial intelligence.

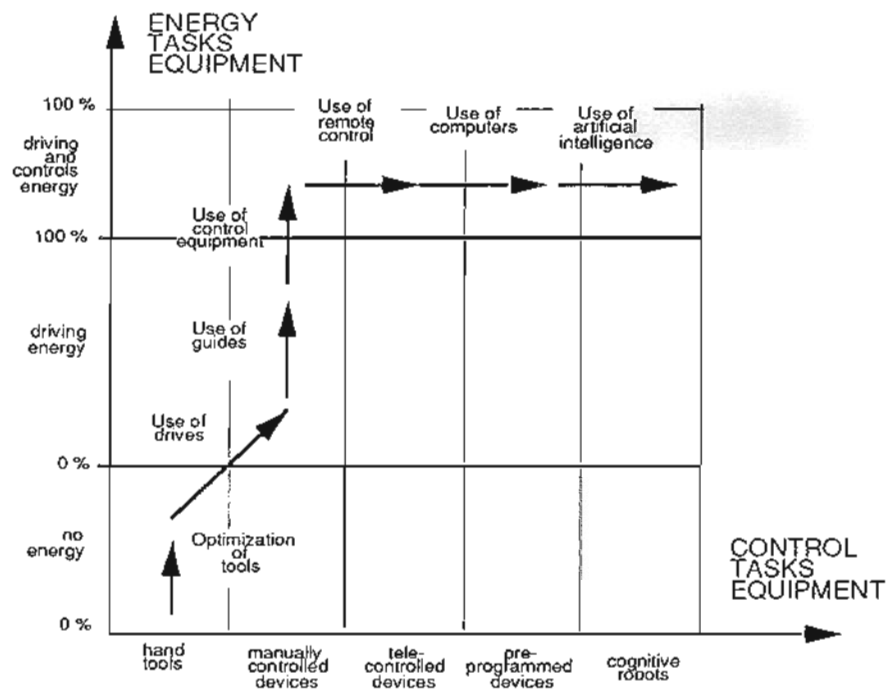

Figure 6. Mechanization phases.

A chain of mechanization phases can also be represented on the graph. The smoothing of a poured concrete floor is used as an example. Traditionally, these concrete floors are smoothed with a hand trowel. The first mechanization phase was the driving of the trowel, which involved manually moving the power trowel over the floor. The next mechanization phase enabled the floor-layer to sit on the machine, so that only operation of the controls was still necessary. Next, the machine was equipped with remote control. The machine was then provided with computer controls that can finish the floor according to programmed instructions. The subsequent step would be to provide computer controls that can make observations and a number of decisions on the basis of these observations.

A distinction can be made between the mechanization of production processes of existing products and modified or new products. Mechanization of existing products is the mechanization of traditional production processes carried out by craftsmen, such as masonry, plastering and carpentry.

Generally it is quite possible to mechanize the energy task, but the

mechanization of control tasks is highly complex.

Just analyse the laying of bricks by a mason and try to put these activities in the operating program of a machine. The mechanization of modified or new products has more of a chance of being put into practice, which is discussed in the following section.

6. PRODUCT AND PROCESS DEVELOPMENT GRAPH

The mechanization phases more or less reflect the development of a process development process. It is also interesting to consider the extent of product modification. What developments can be distinguished for the materials to be processed? In figure 7, the product and process developments have been plotted out on a graph.

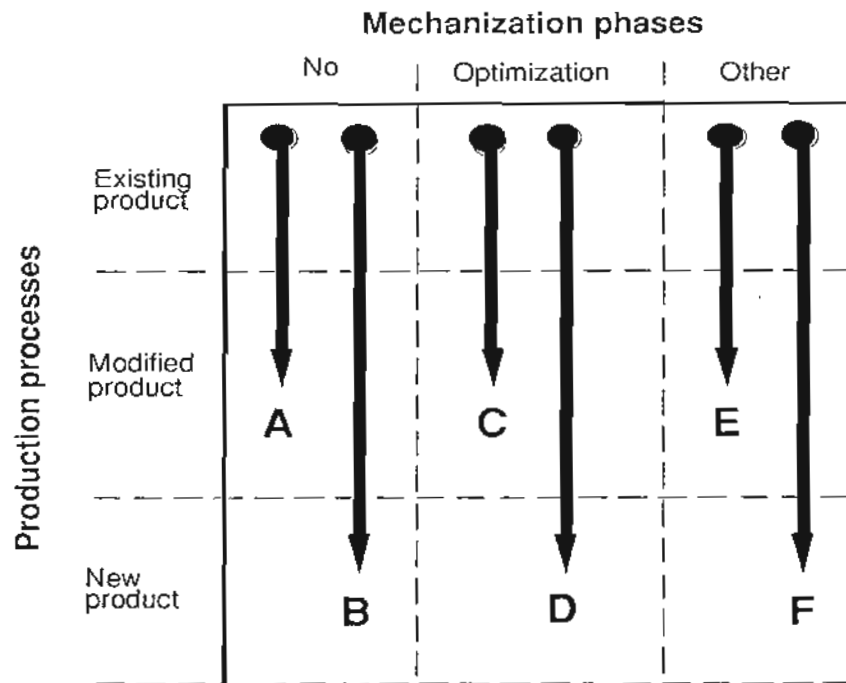

Figure 7. Product and process development graph.

The arrangement below is used for process developments:

- no mechanization phase
- optimization and
- other mechanization phases.

The arrangement is for production processes:

- existing product
- modified product and
- new product.

Six development phases can now be distinguished in the graph.

Examples of them are:

- A: The improvement of the dimensional accuracy of products.
- B: The manufacture of tiles from concrete instead of clay.
- C: The furnishing of building blocks with grips.
- D: The gluing of limestone blocks.
- E: The supply of dry masonry mortar in large steel silos.
- F: The manufacture of large limestone elements that have to be assembled with a precision crane.

It is easy to see that mechanization of production processes on the building site offers the most possibilities when product development can take place at the same time.

7. FUTURE DEVELOPMENTS

In the short term, production processes according to traditional methods, the energy tasks - particularly the driving energy - can be mechanized to an even greater extent, i.e. the stacking of building bricks and the transport of mortars. In the medium term, the Advisory Committee For Technological Policy in the Building Industry (Adviesraad Technologiebeleid Bouwnijverheid - ARTB) predicts in its publication *Building Outlook for 2010 (Bouwvisie 2010)* that the building site is increasingly becoming an assembly site for pre-fabricated building products [ARTB]. Accordingly, the equipment people use on the building site should be developed in relation to building products. The energy tasks workers still carry out then will be minimal and ergonomically sound. Workers will continue to perform control tasks. In the longer term, mechanization of control tasks will also occur, i.e. robotization.

REFERENCES

ARTB Bouwvisie 2010, 1993. A study commissioned by the Dutch government in order to outline the future building market.

Guo, S. and Tucker, R., 1993. Automation needs determination using the AHP approach, in the proceedings of the 10th International Symposium on Automation and Robotics in Construction (ISARC X), Elsevier Amsterdam.

Maas, J.G. Modernization by considering the total building process. *De Ingenieur (Engineer)*, no. 3 (March 1991).

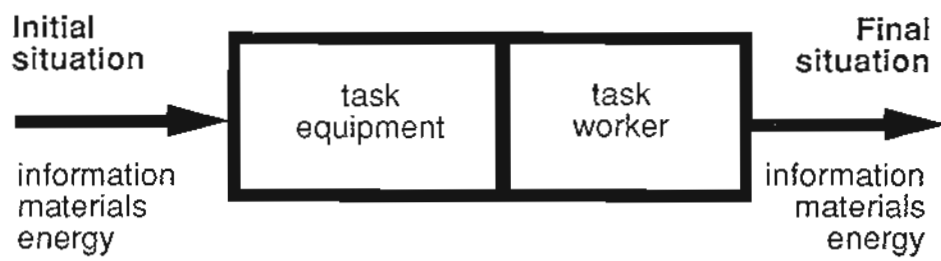

WORKER EQUIPMENT SYSTEM

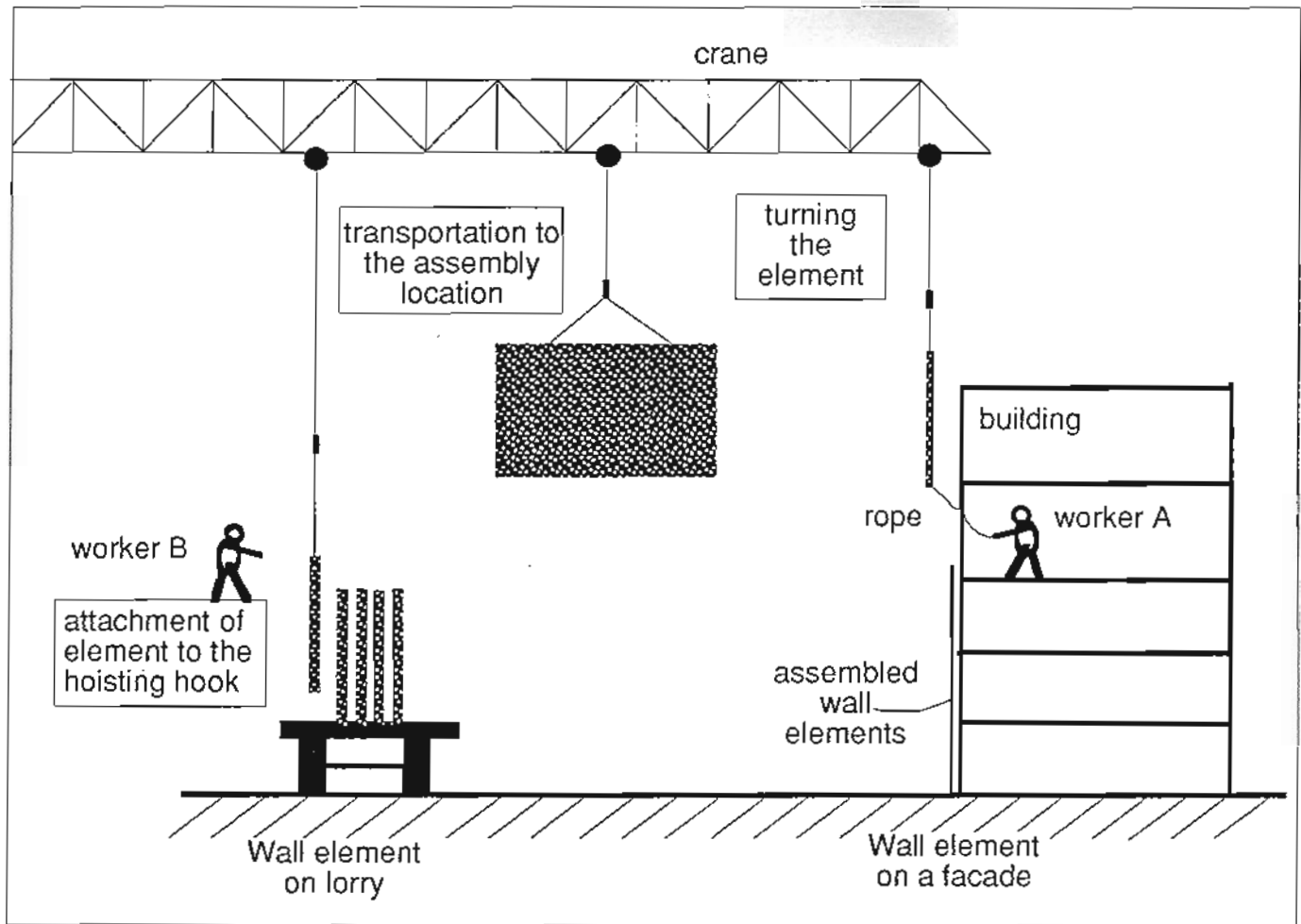

PLACING WALL ELEMENTS

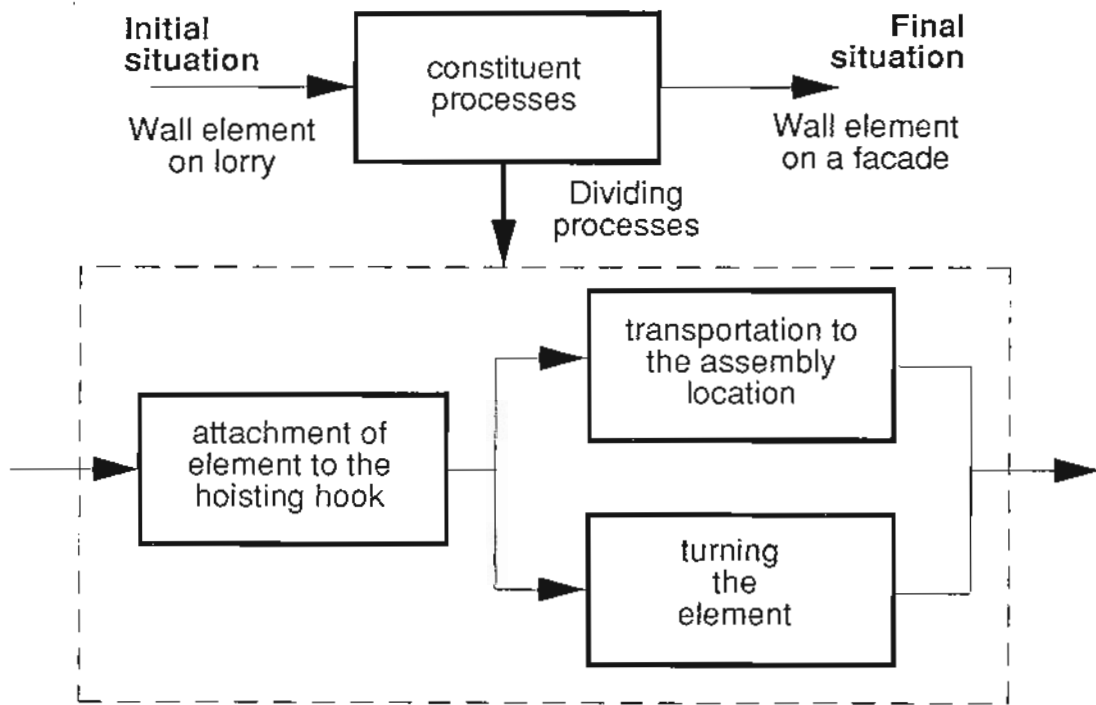

TRANSPORTATION OF WALL ELEMENTS

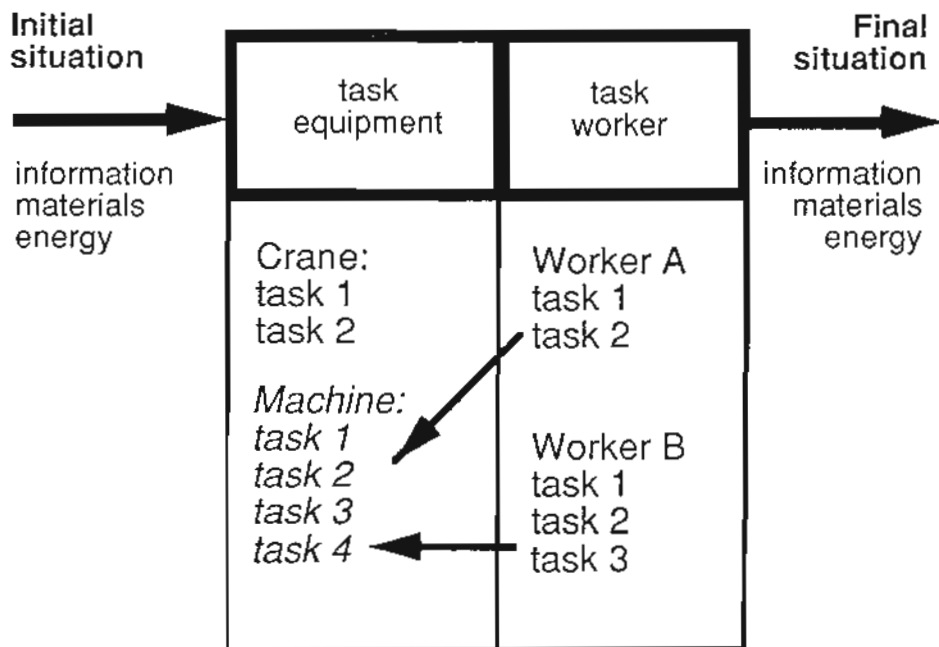
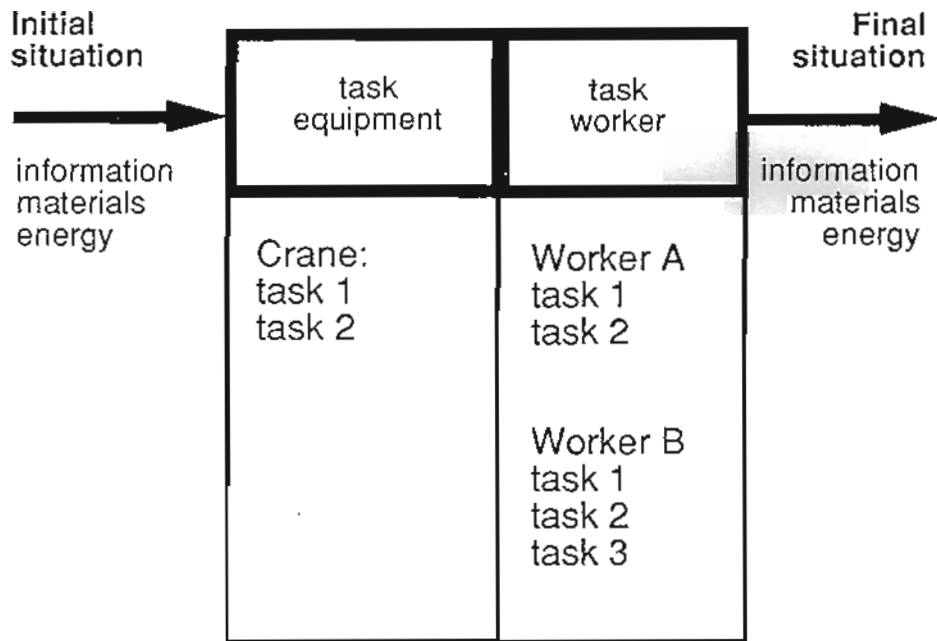

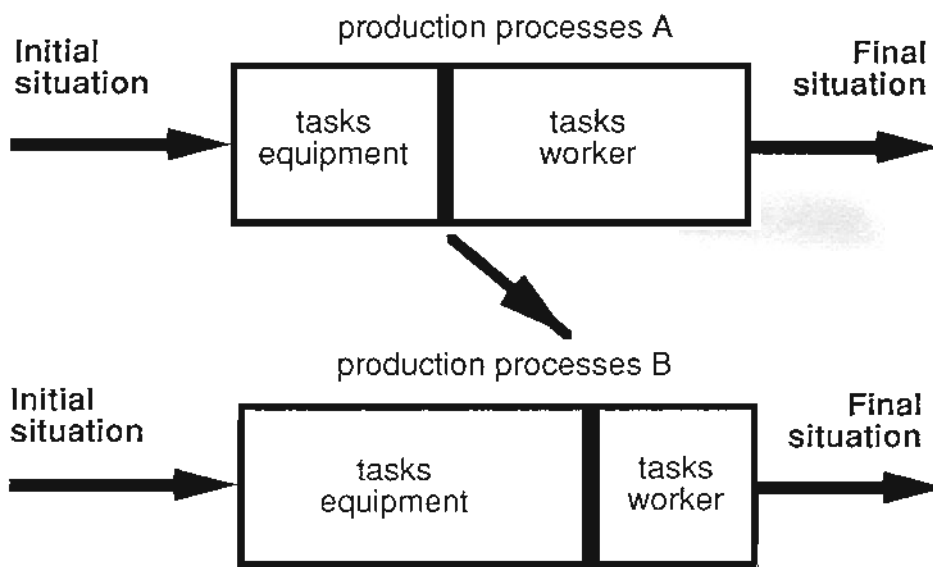

THE MECHANIZATION CONCEPT

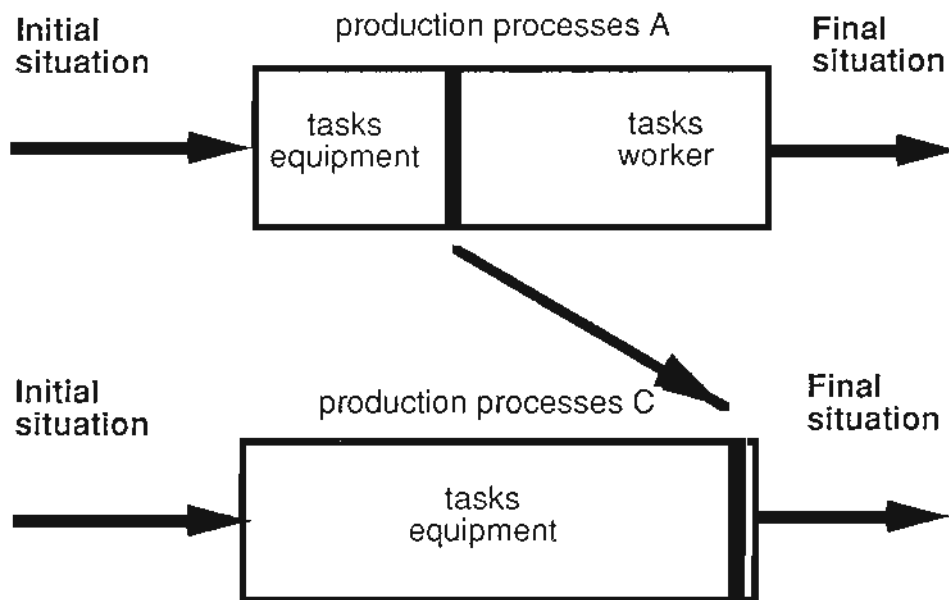

THE ROBOTIZATION CONCEPT

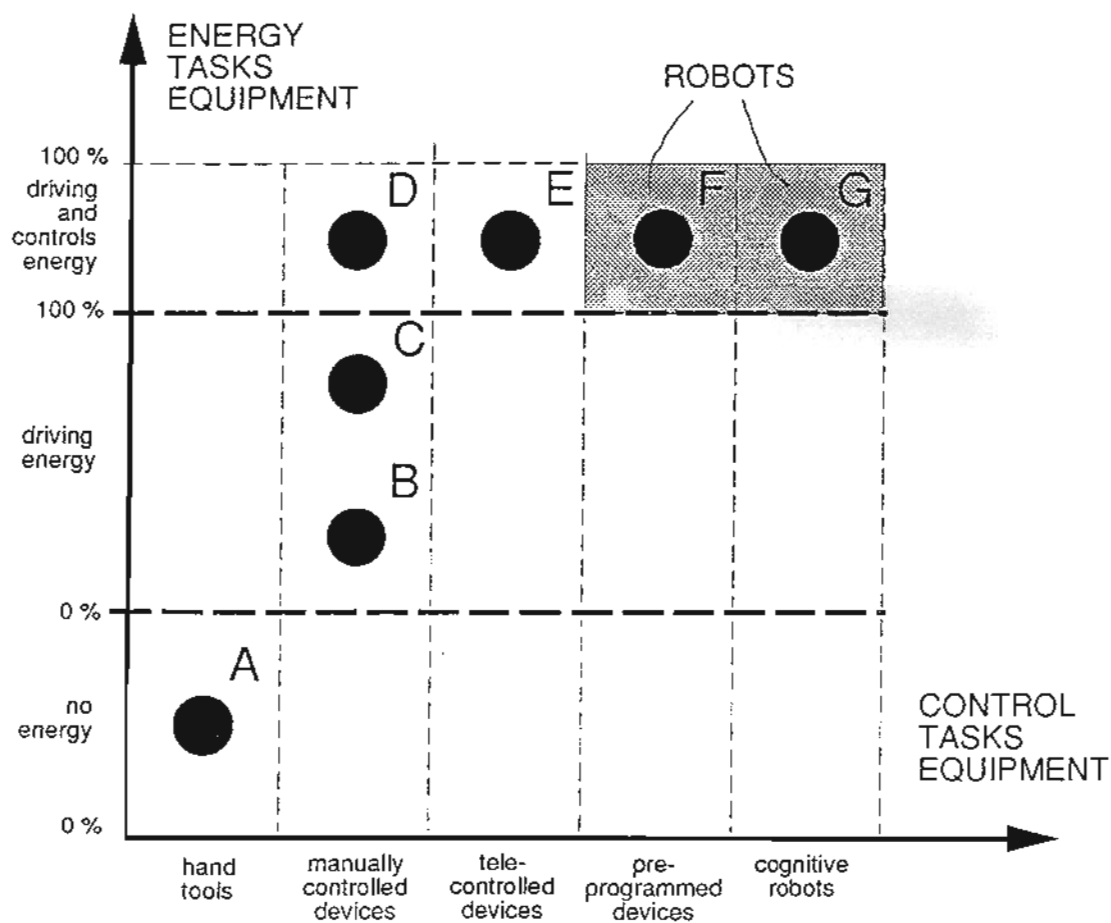

MECHANIZATION GRAPH

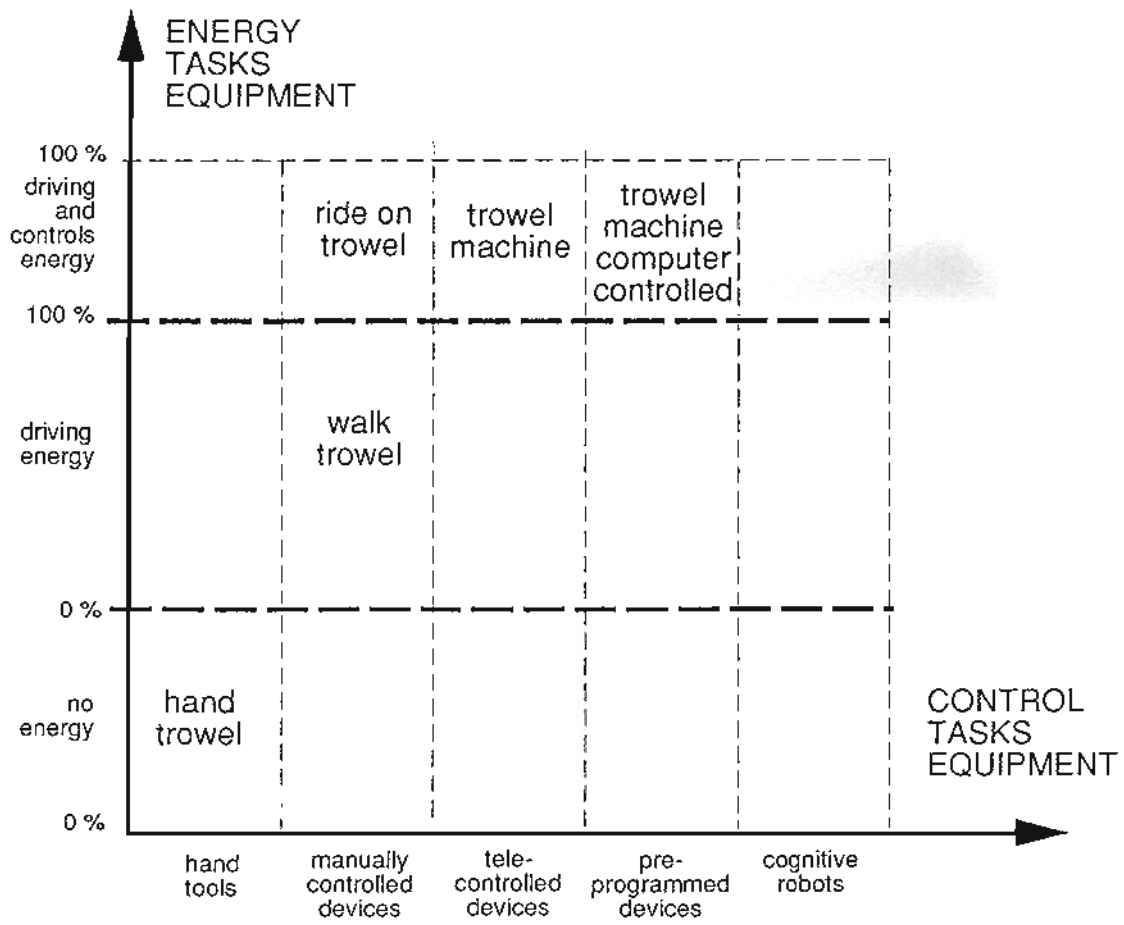

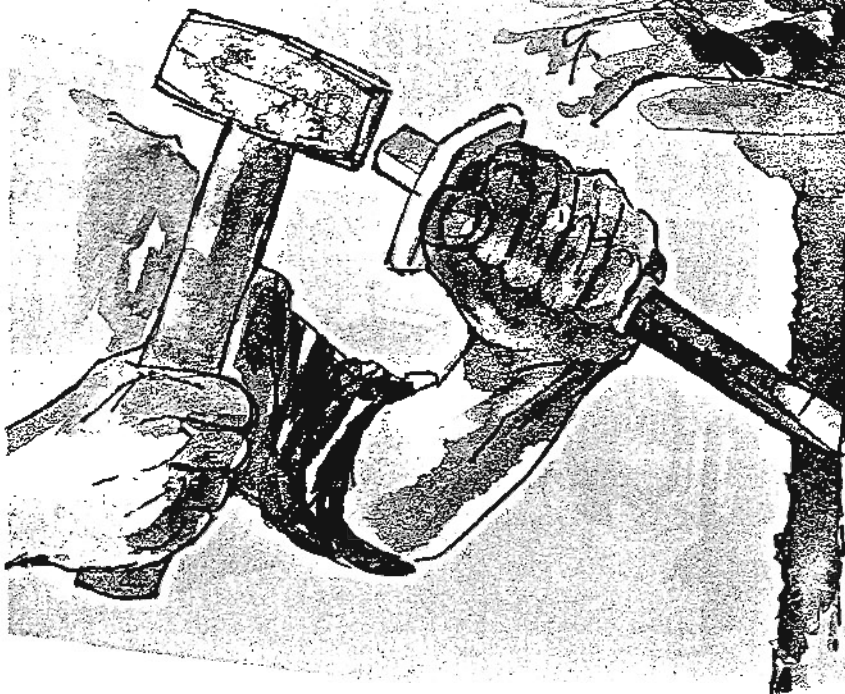
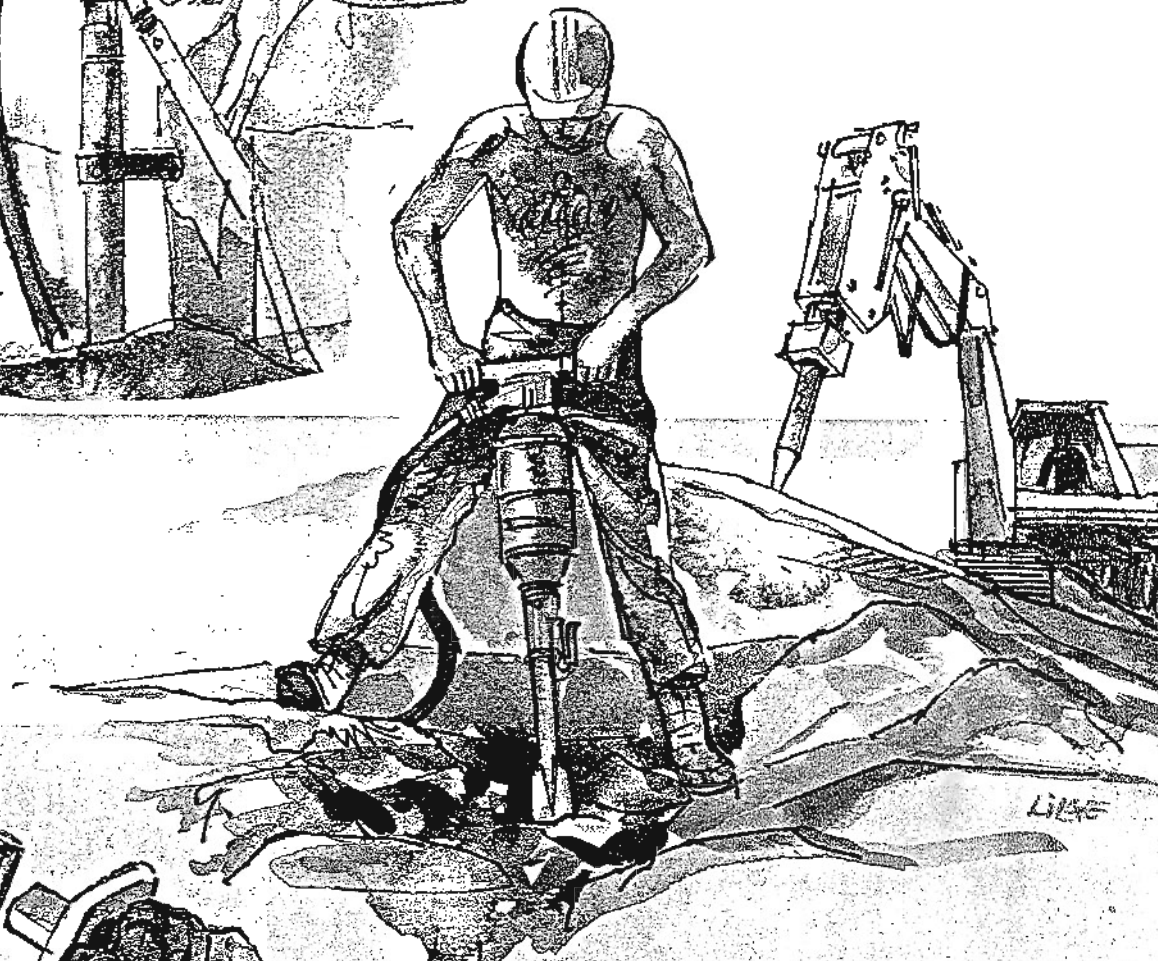

LISE

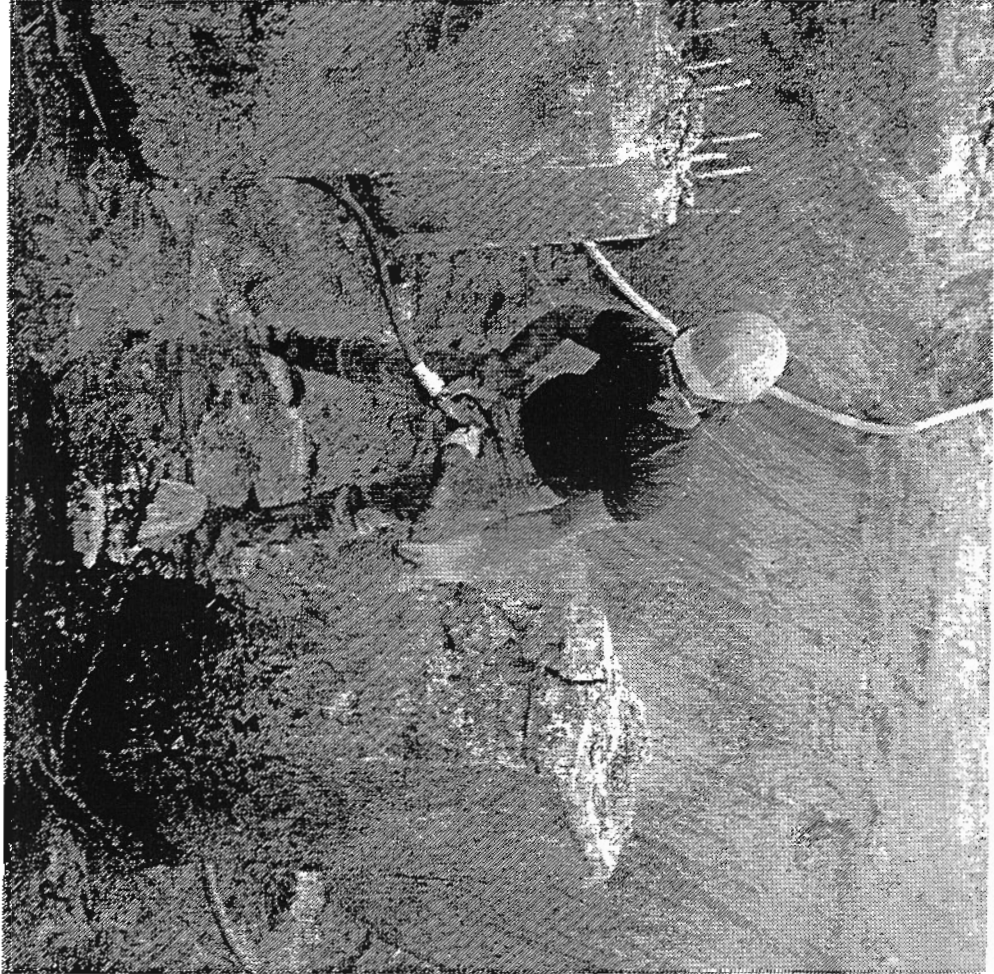

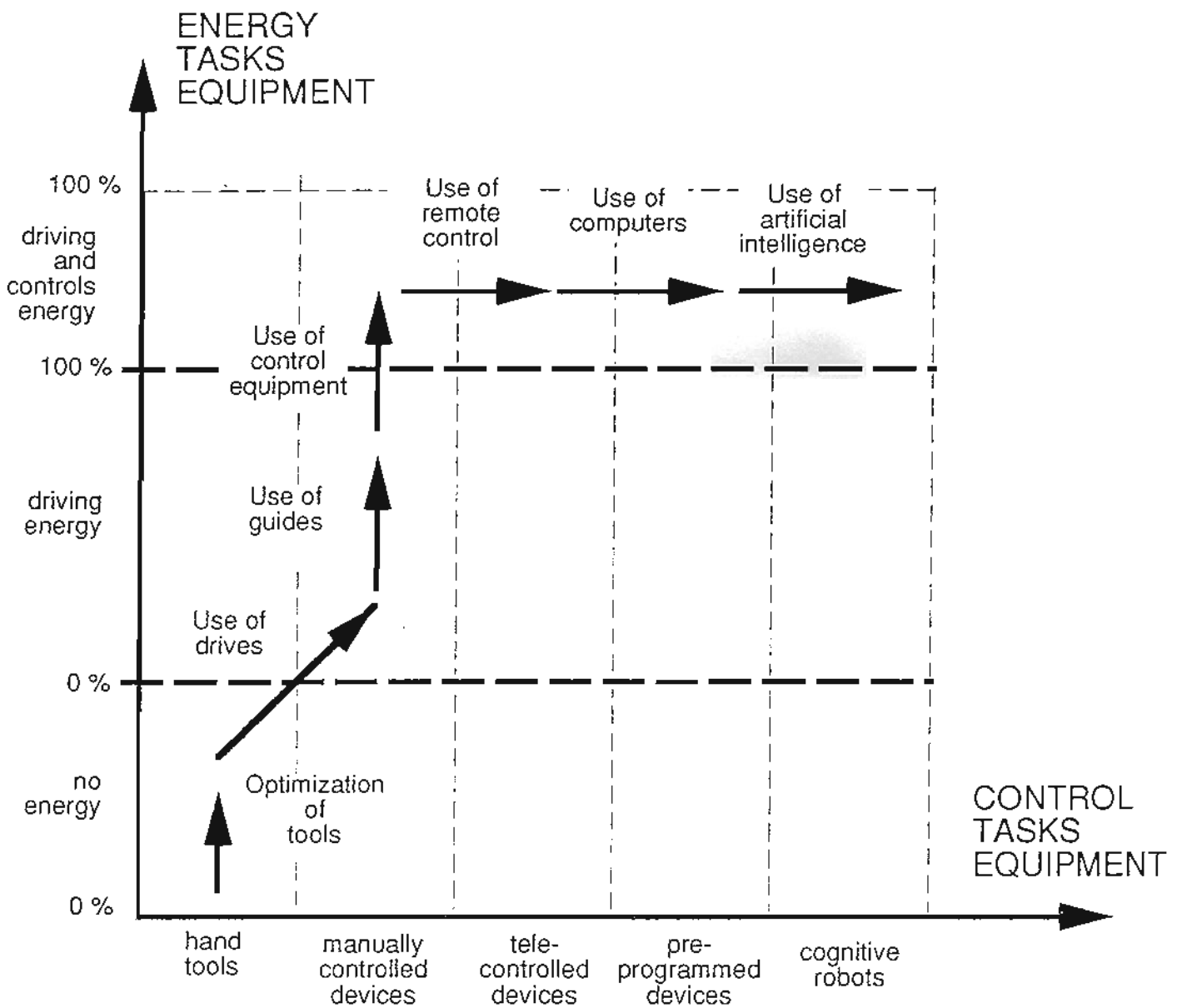

MECHANIZATION PHASES

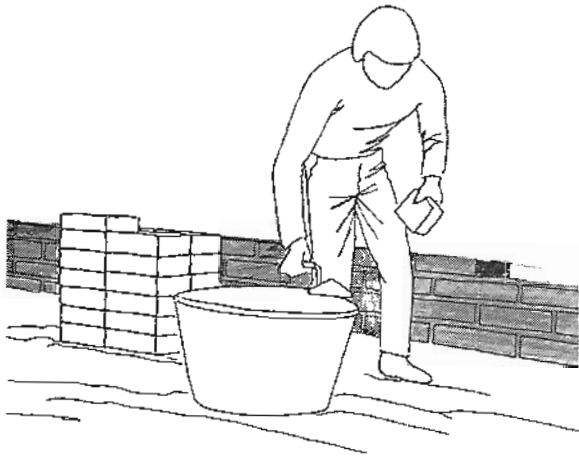

OPTIMIZATION OF TOOLS





OPTIMIZATION OF TOOLS





USE OF DRIVES

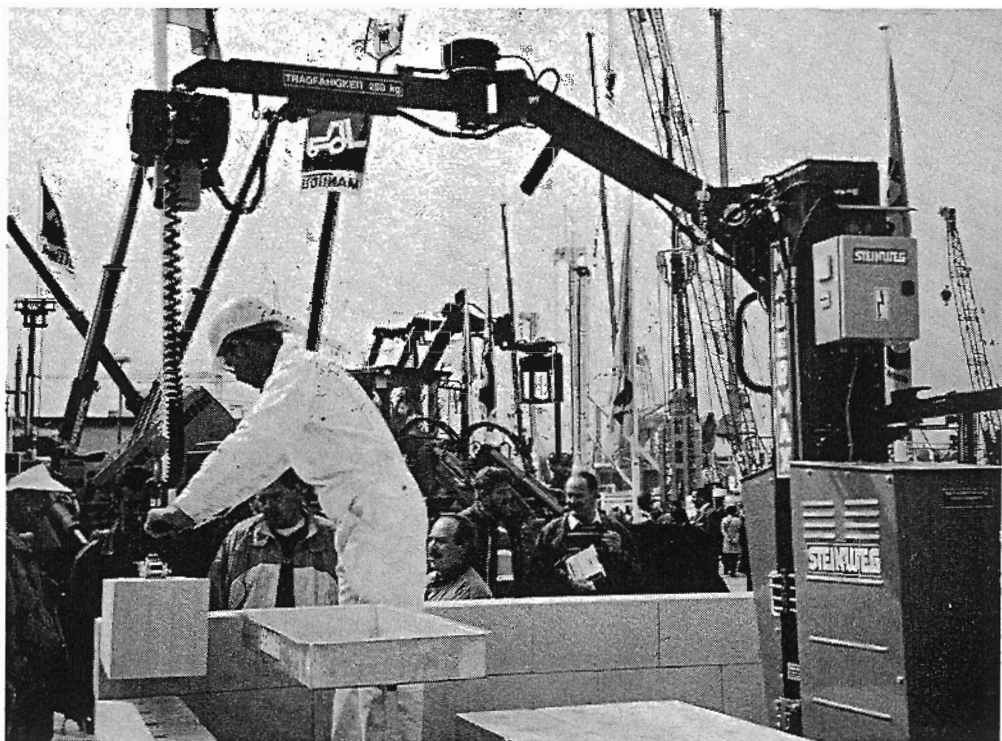

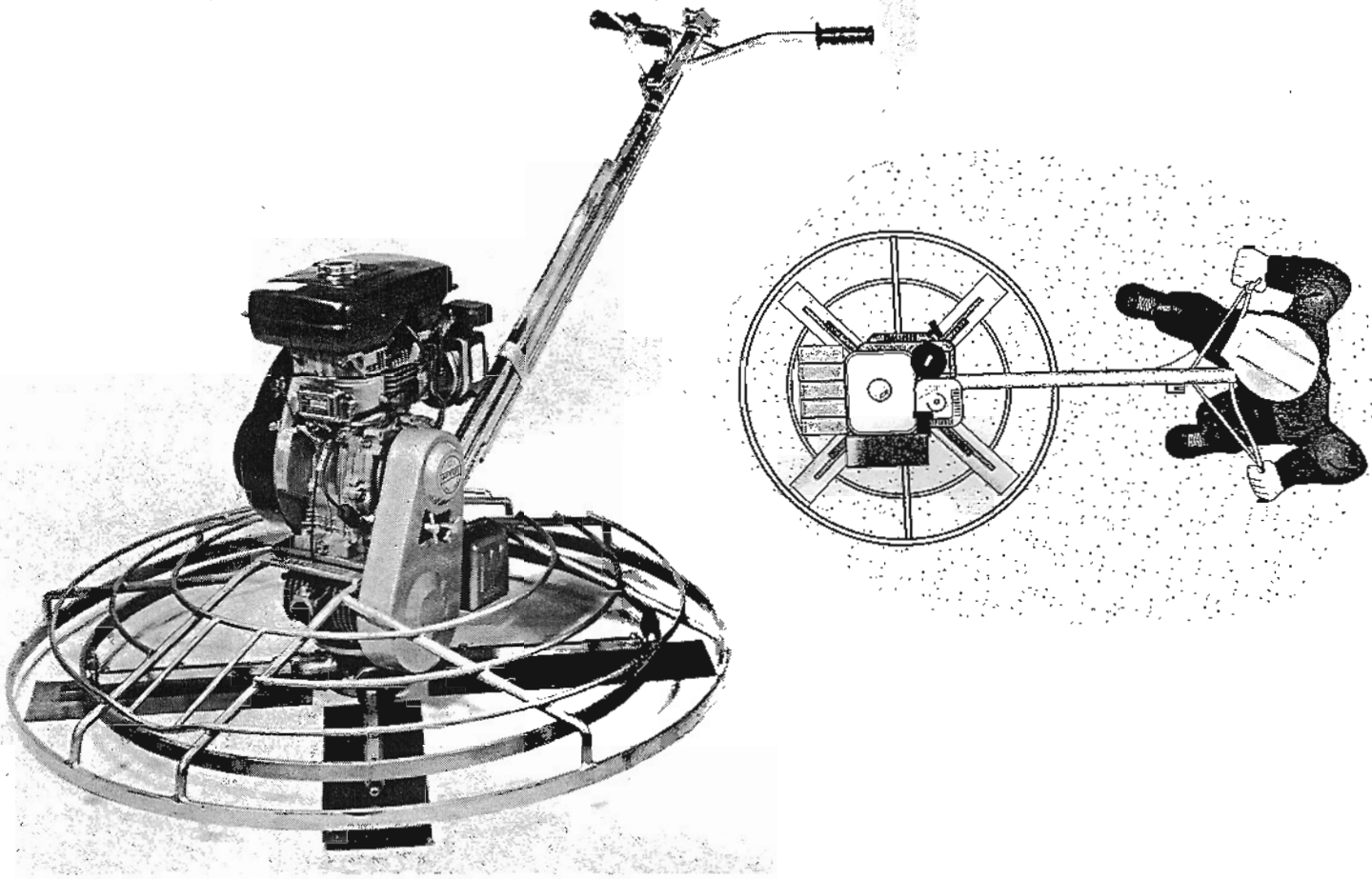

USE OF CONTROL EQUIPMENT

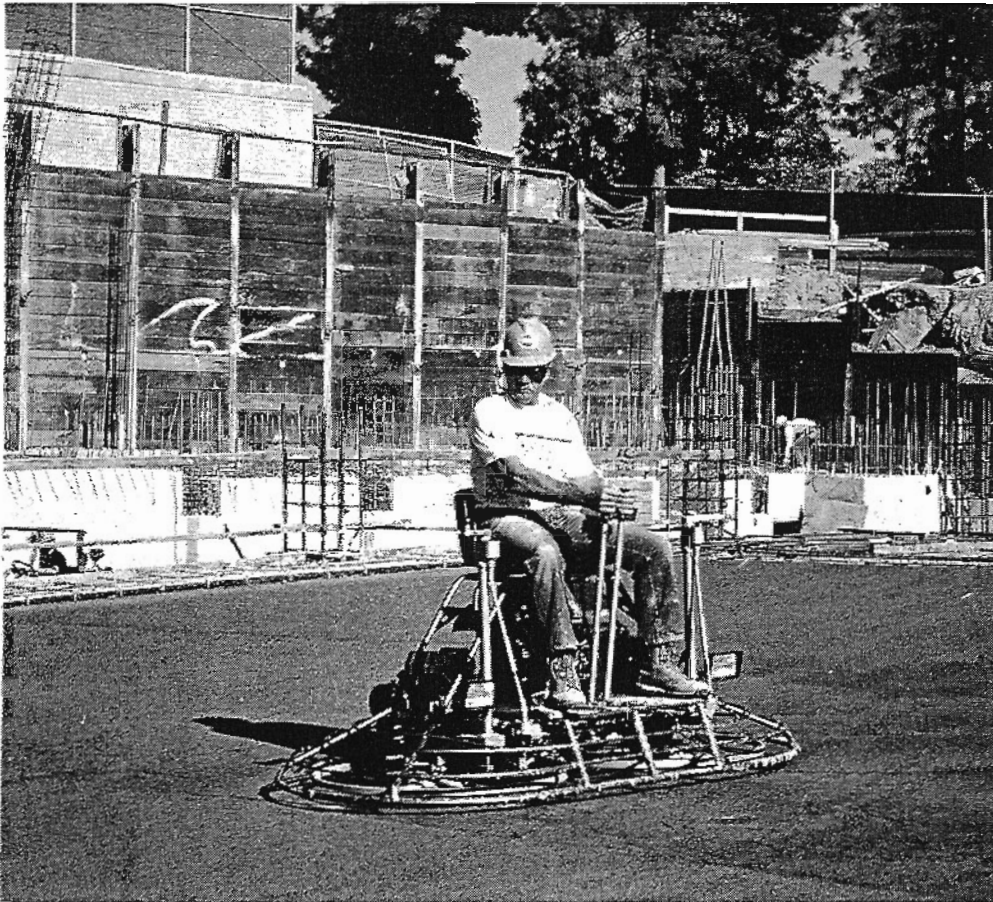

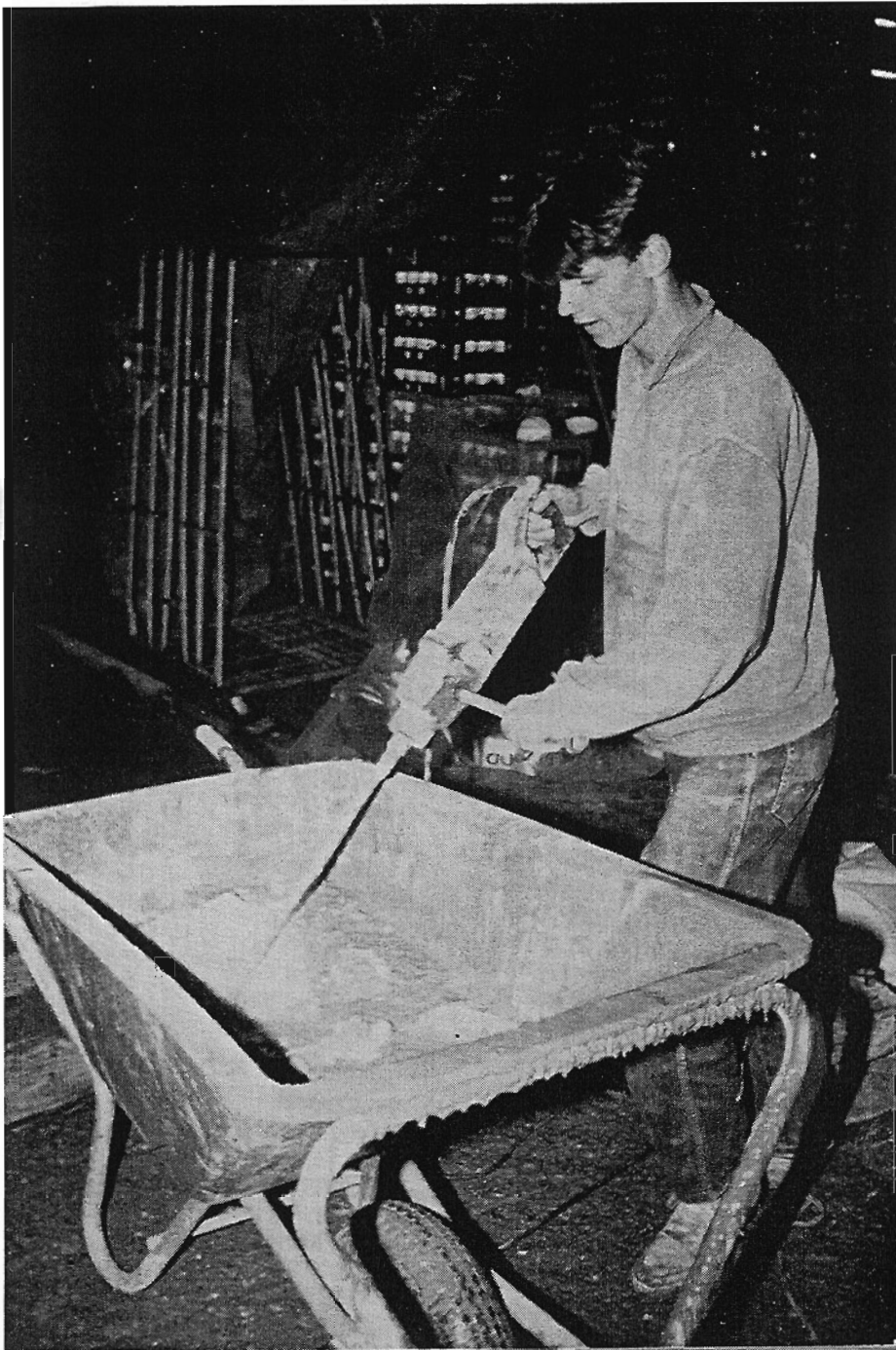

USE OF DRIVES

USE OF GUIDES



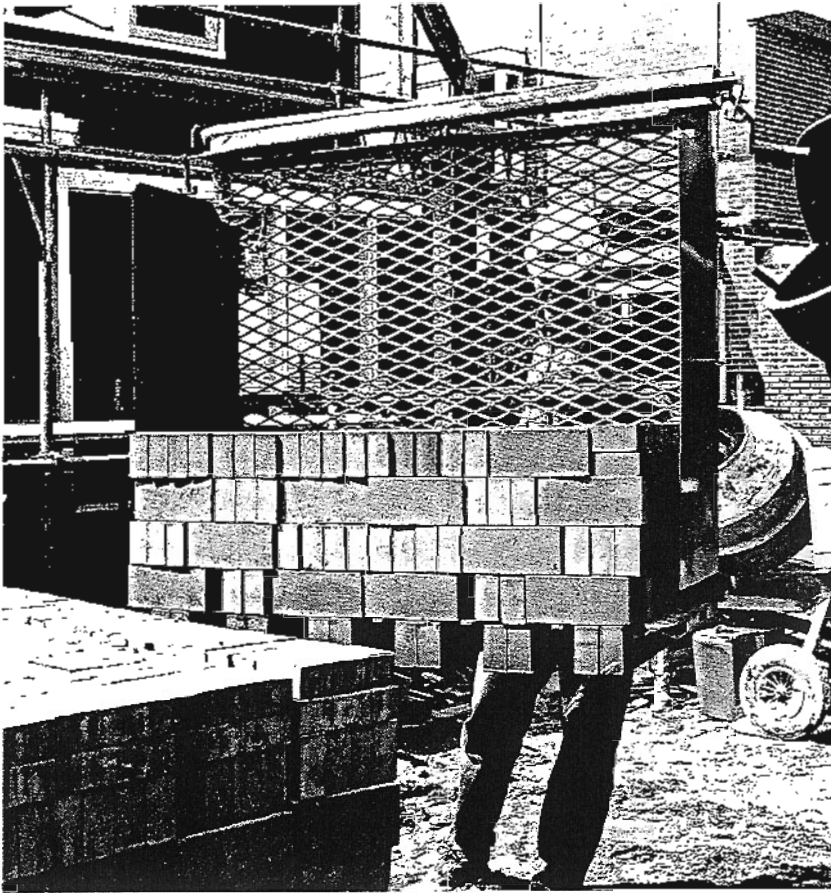

USE OF GUIDES

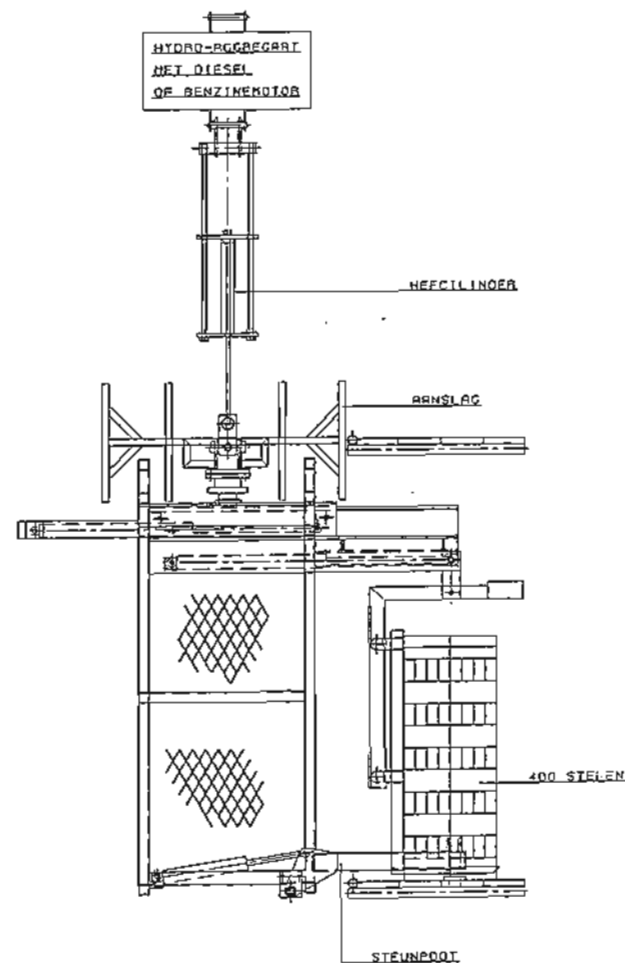
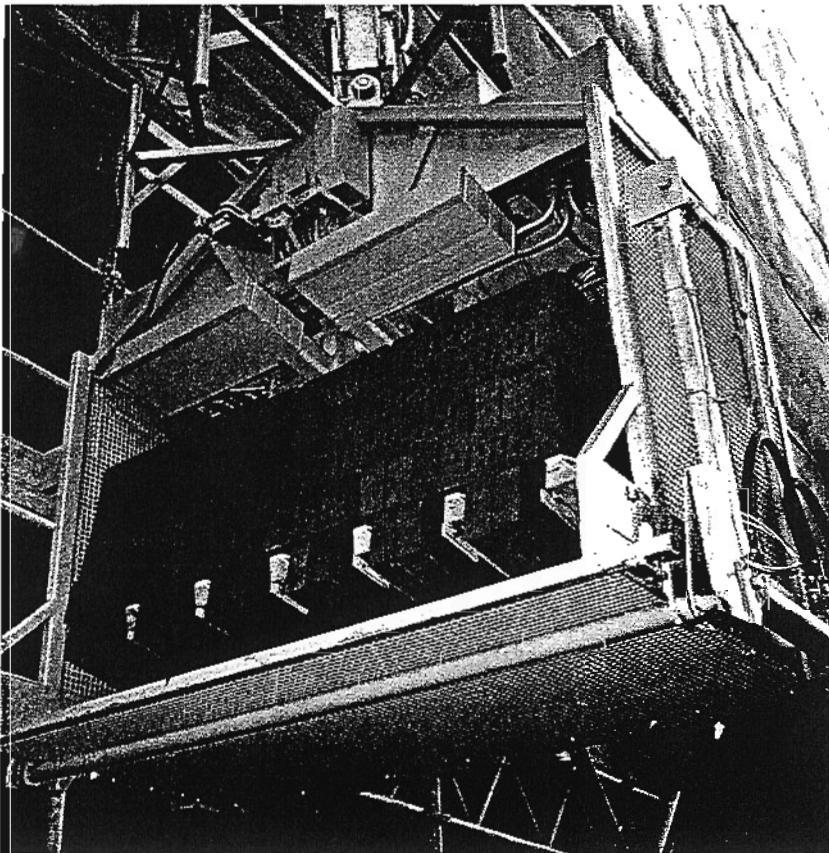

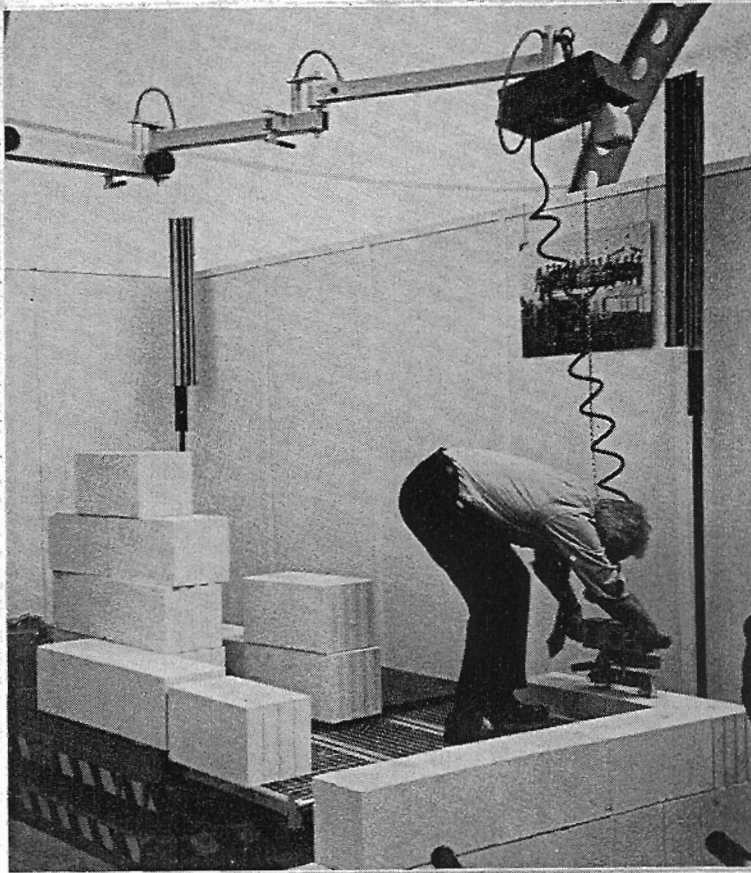

USE OF COMPUTERS

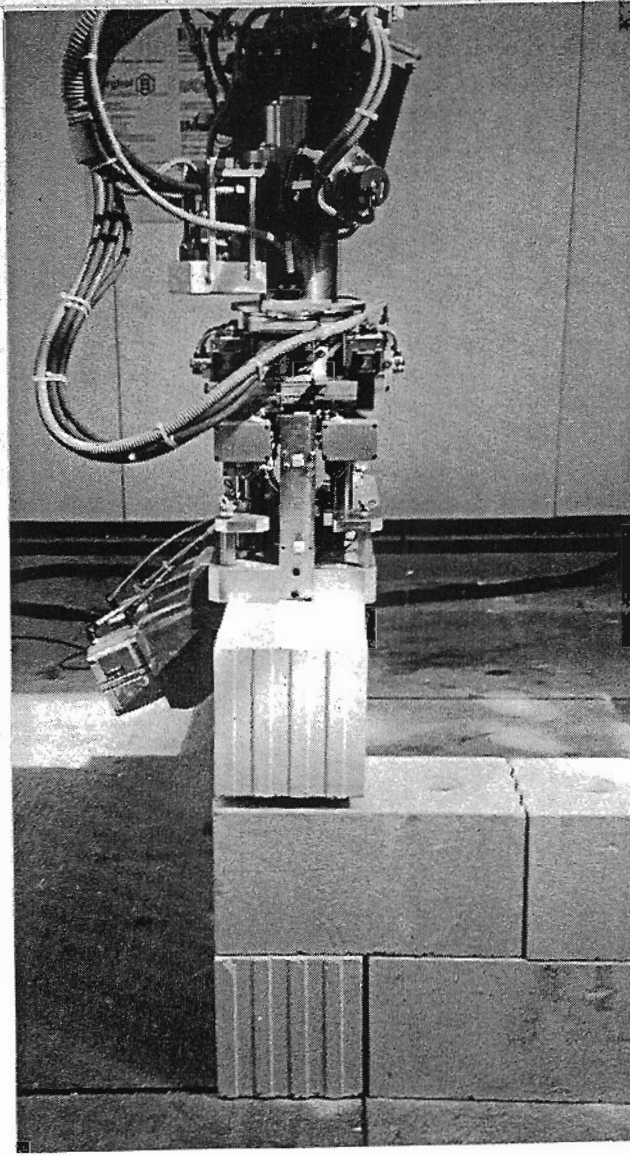
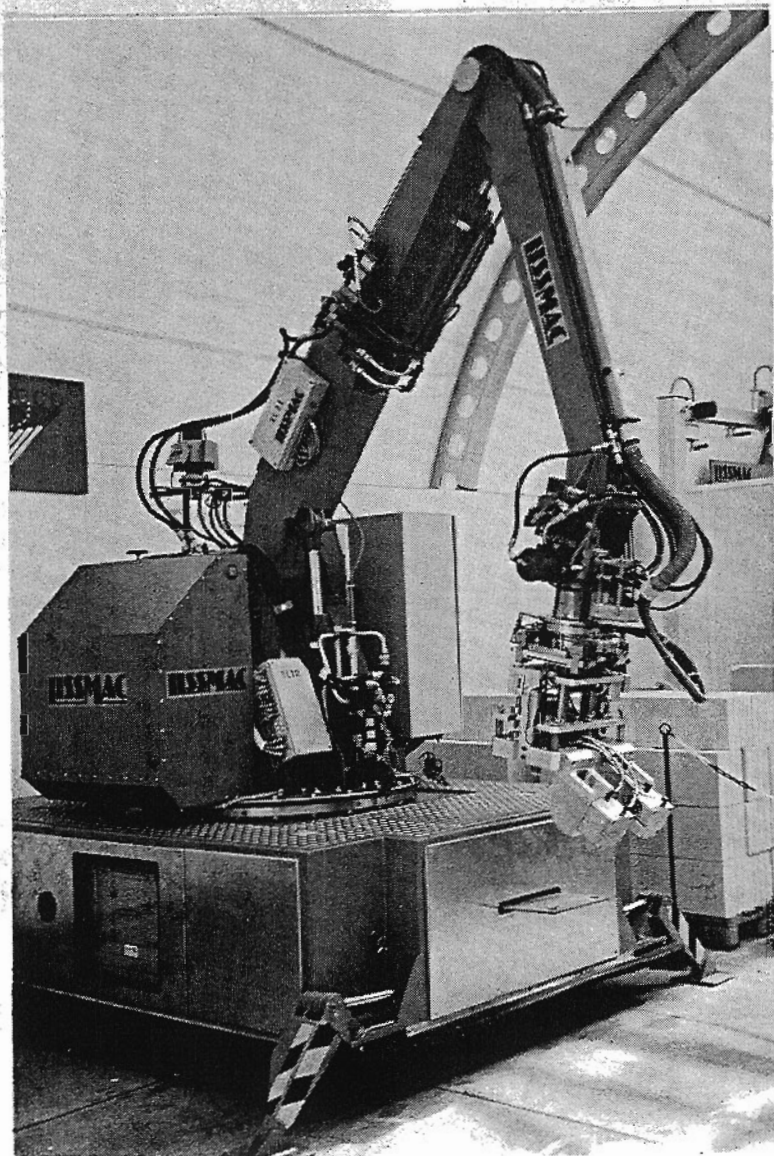

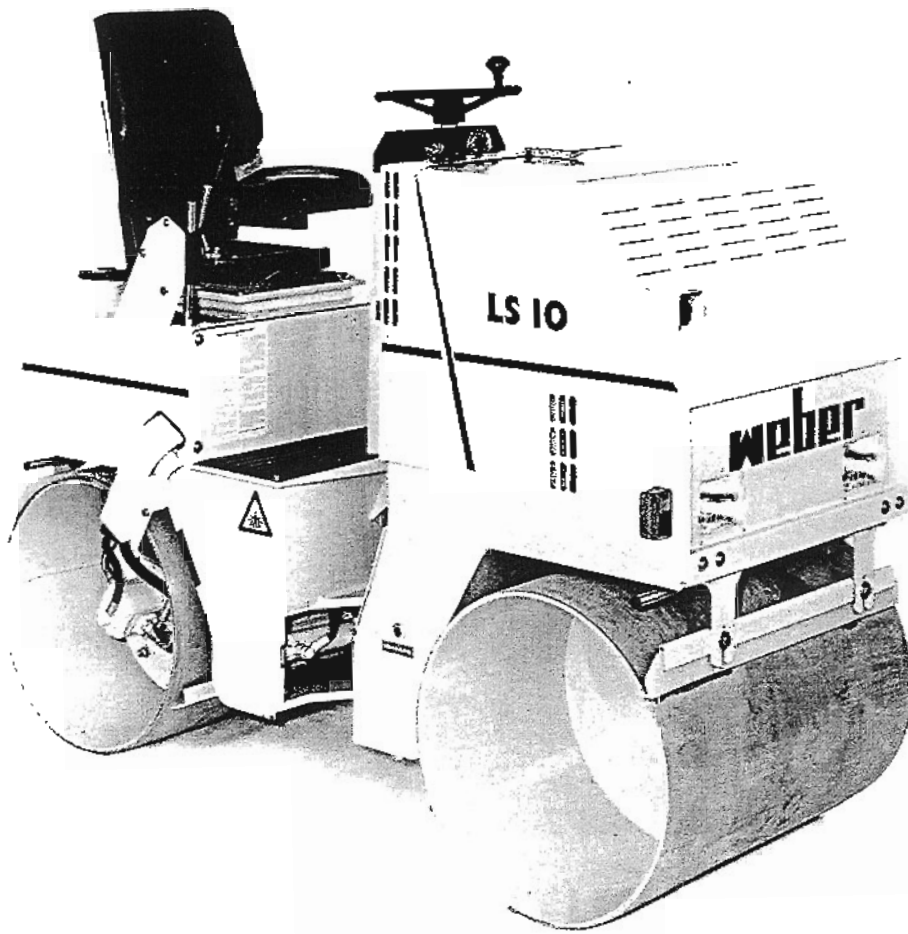

USE OF REMOTE CONTROL

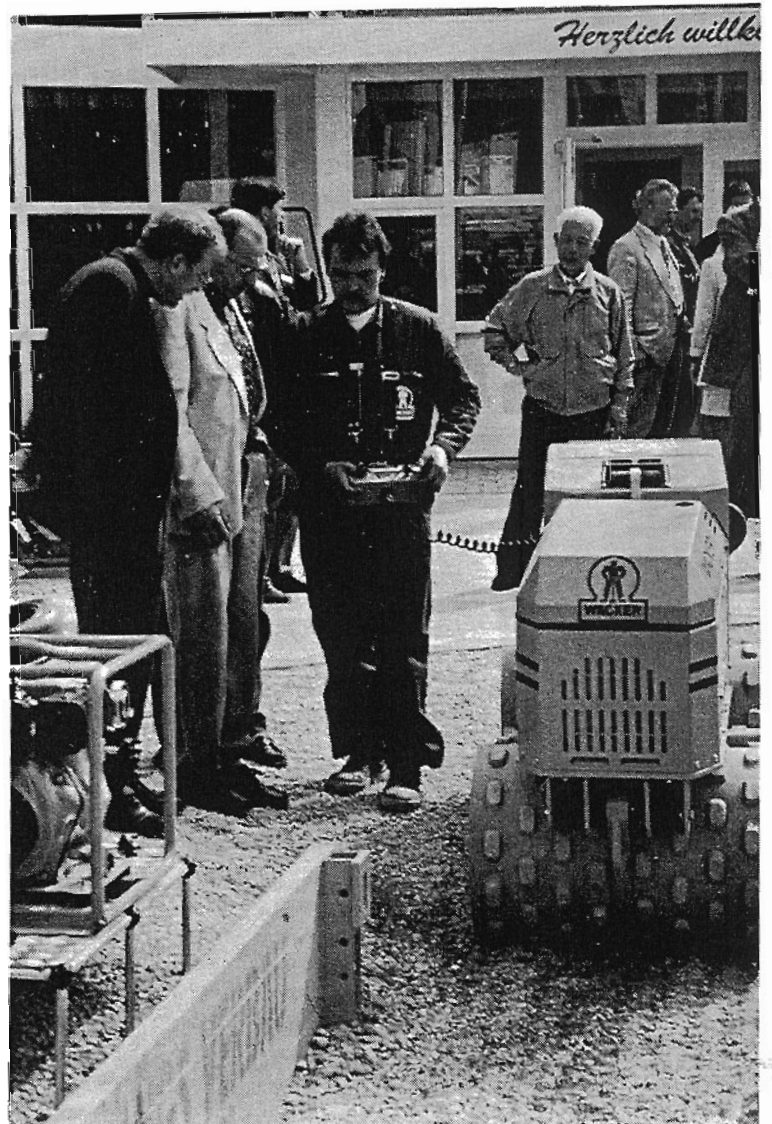

Two Block Warning/Limit System components

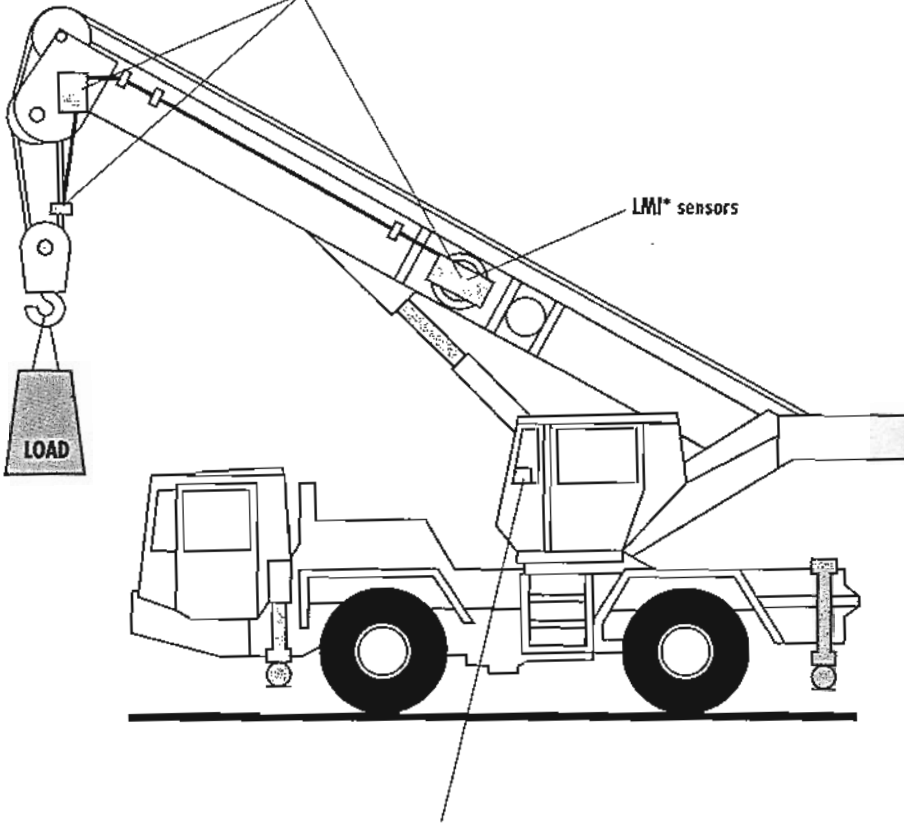

Full graphic display in the cab gives the operator access to all critical crane information. Keypad also allows the operator to input or request information.

USE OF SENSORS

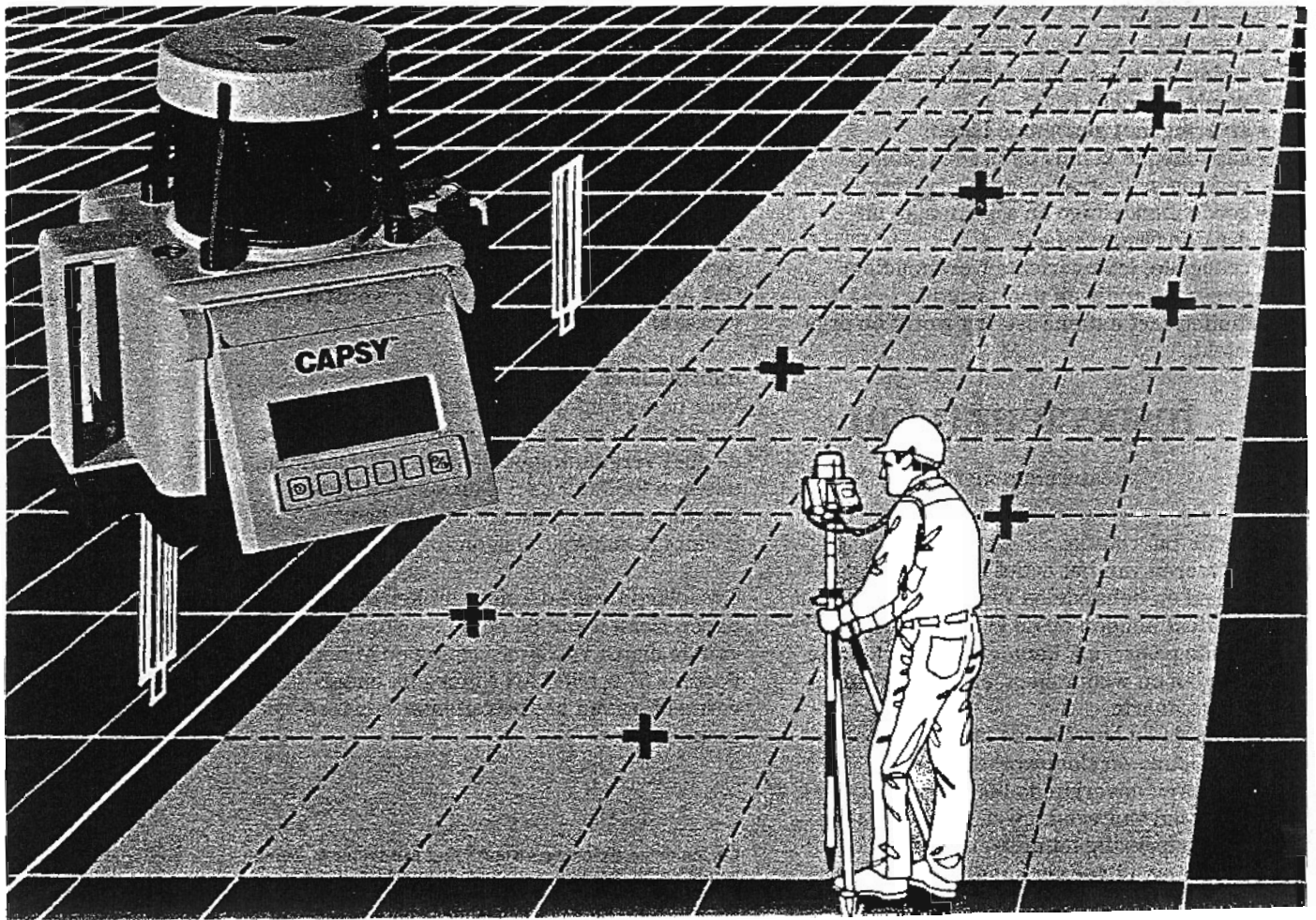

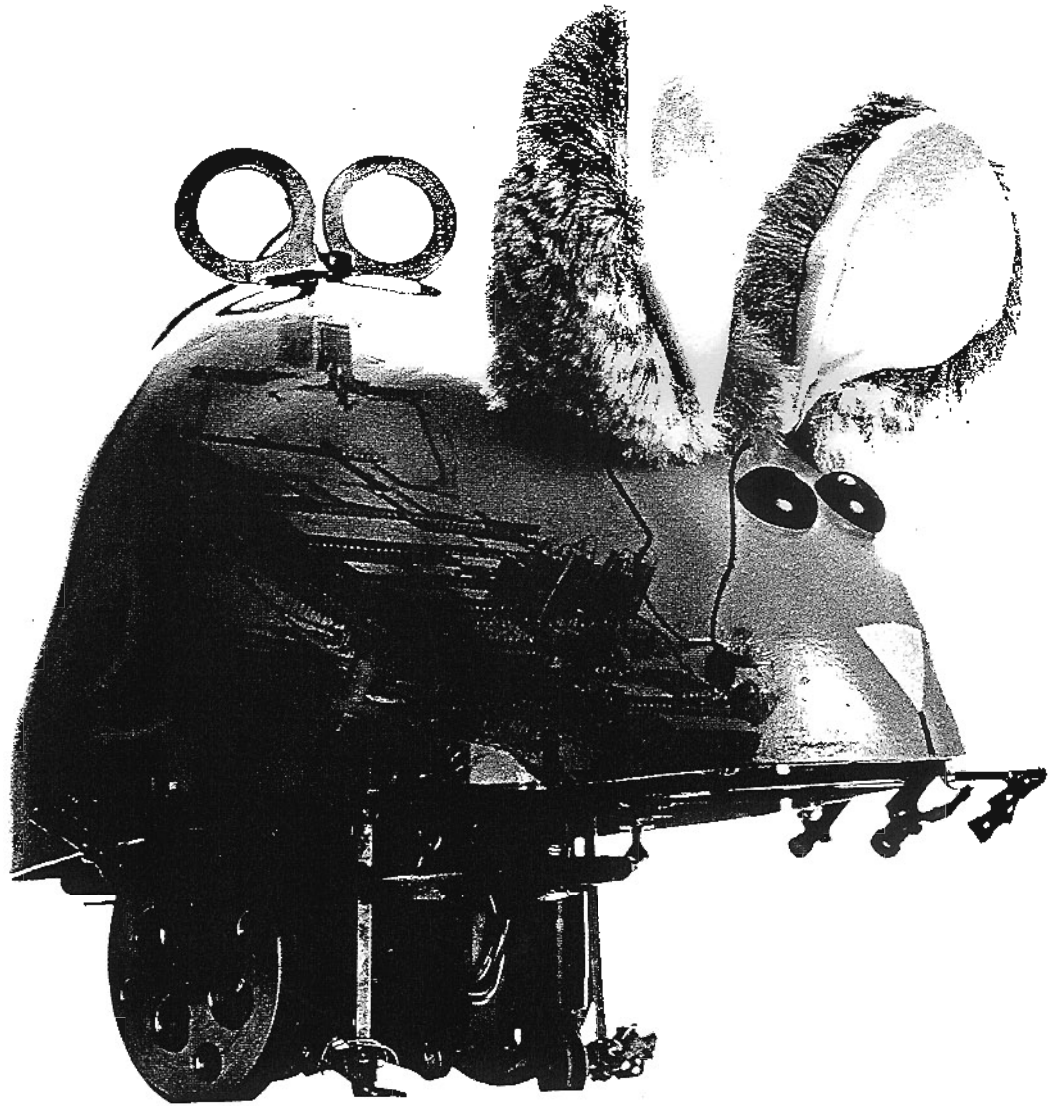

USE ARTIFICIAL INTELLEGEANCE

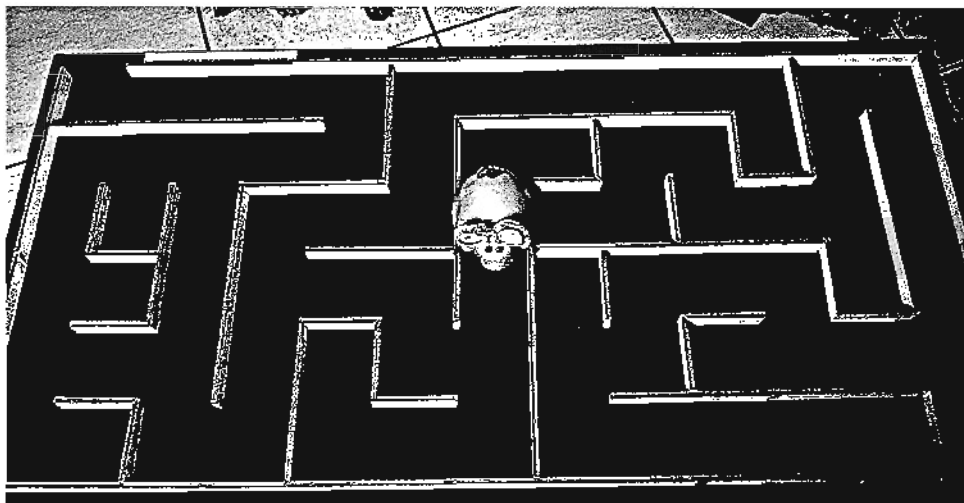

Mechanization phases

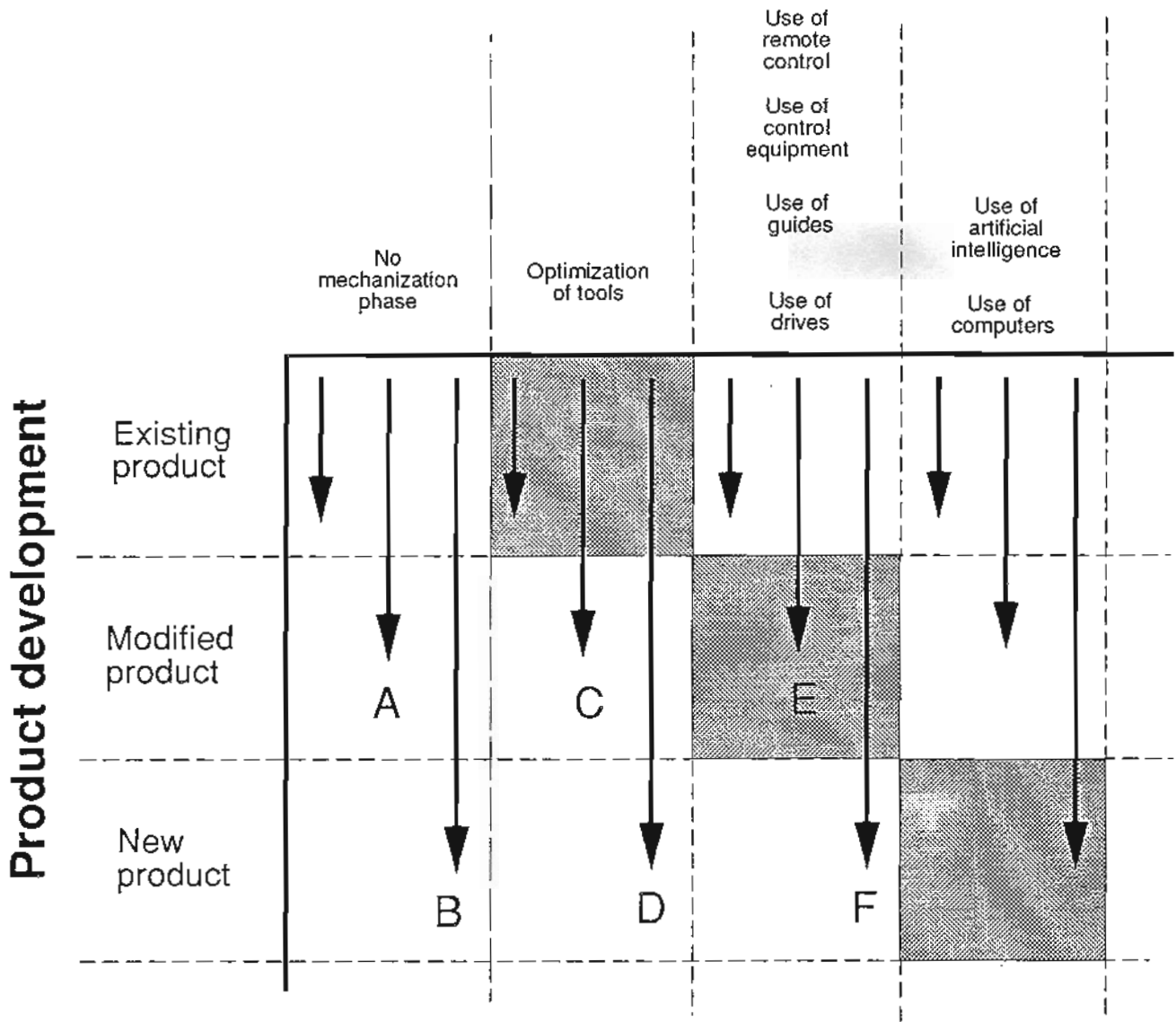

PROCESS AND PRODUCT DEVELOPMENT

KNOWLEDGE

- MATERIALS AND CONSTRUCTION PRODUCTS
- WORK METHODS
- WHAT WORKERS CAN DO (ERGONOMICS)
- DRIVE TECHNOLOGY, GUIDES AND MANIPULATORS
- MACHINE CONTROLS, REMOTE CONTROLS AND PROGRAMMING TECHNOLOGIES
- SENSORS AND ARTIFICIAL INTELLIGENCE